

Sentinel LCT8 High Accuracy Ultrasonic Flow Meter



Certainty Delivered

In an industry where reliability and performance are measured in terms of uncertainty, it's imperative to choose instrumentation that provides peace of mind. The Sentinel LCT8 is the newest addition to the Panametrics line of ultrasonic flow meters for high-accuracy metering applications.

Used primarily for measuring hydrocarbon liquids and water for critical use, the eight-path design of the LCT8 enables the meter to maintain performance in unstable conditions. Its eight chordal paths provide a stratified field that cancels the effect of swirl and flow disturbances caused by changing fluid properties or installation effects. Sentinel LCT8 delivers certainty in uncertain processes.

The LCT8 incorporates the groundbreaking design of the Sentinel LCT4, seamlessly integrating into a pipeline or process. When a smaller installation footprint is required or pressure drop is concerned, the eight-path design allows for shorter upstream and downstream lengths.

Against other flow technology meters, the LCT8 exemplifies the advantages of ultrasonic flow measurement, including:

- No drifting or required periodic calibration
- No pressure drop
- No restriction in the pipe
- No moving parts and no filters or strainers

A True Multi-Viscosity Meter

The LCT8 uses a number of proprietary algorithms to reduce viscosity effects, making it viscosity independent. No prover run or change of settings is required when the viscosity changes. The meter retains its accuracy over the whole range between minimum and maximum viscosity, using only one calibration curve.

Applications

- Pipeline leak detection
- Liquid custody transfer measurement
- Allocation measurement
- Any critical liquid process



Calibration

Laboratory calibration on the LCT8 is performed to match the application, using either a single fluid or multiple fluids. Each meter is calibrated to adhere to the OIML R117-1 international standard. Other specific calibrations are available upon request.

There is no need for recalibration when replacing transducers or electronics. Testing by NMI as part of the OIML certification is pending.

Advanced Electronics

The Sentinel LCT8 electronics has digital signal processors that pack significant power in a simple package. As a standard package, several inputs and outputs are available, including Modbus. The electronics is integrated with the flowcell body in a single unit, but can also be mounted remotely using an adapter and cable.

Local programming and diagnostic access is done via magnetic induction to preserve hazardous area integrity. USB and RS232 connections are available to link with GE's PanaView software.

PanaView™ Diagnostics

The PanaView software facilitates communication between the Sentinel LCT8 and a PC. Not only does this software provide real time flow data, but it is also capable of providing historical tracking of diagnostics and a full configuration audit trail. The PanaView diagnostic master screen is shown below.

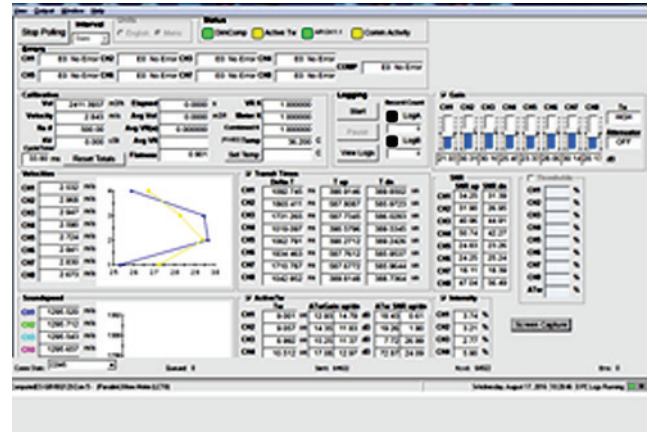

System Weights



Vessel Nominal Diameter	Fully Assembled Dry Weight					
	English [lb]			Metric [kg]		
	150#	300#	600#	150#	300#	600#
6"	239	286	346	108	130	157
8"	334	398	497	151	181	225
10"	421	512	694	191	232	315
12"	582	704	896	264	320	407
14"	746	925	1077	339	420	488
16"	978	1200	1469	444	545	666
24"	2112	2660	3202	958	1207	1453

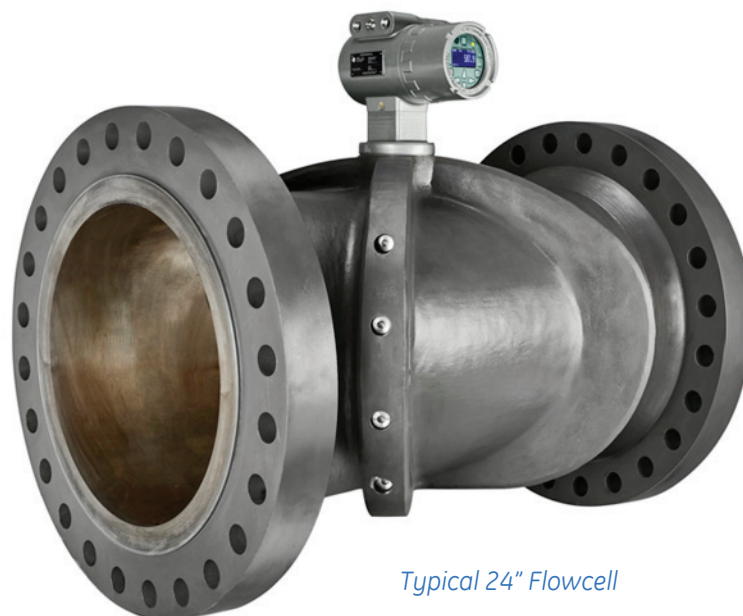

Typical 24" Flowcell

Flow Ranges

Nominal Size	Velocity					Volumetric ^{2,3}					
	in.	mm	ft/s	ft/s	m/s	m/s	Qmin	Qmax	Qmin	Qmax	Qmin
6	150	1	40	0.3	12.2	20	818	90	3602	129	5147
8	200	1	40	0.3	12.2	35	1417	156	6237	223	8913
10	250	1	40	0.3	12.2	56	2233	246	9831	351	14049
12	300	1	40	0.3	12.2	80	3203	353	14100	504	20150
14	350	1	40	0.3	12.2	98	3905	430	17191	614	24566
16	400	1	40	0.3	12.2	129	5172	569	22772	814	32542
18	450	1	40	0.3	12.2	165	6618	728	29137	1041	41637
20	500	1	40	0.3	12.2	206	8241	907	36285	1296	51852
24	600	1	40	0.3	12.2	301	12022	1323	52932	1891	75639

1. Based on nominal sch 40S/STD inner diameter
2. These flowrates comprise product capability.
3. OIML R117 applications will be limited based on ranges detailed in certificate

Dimensions

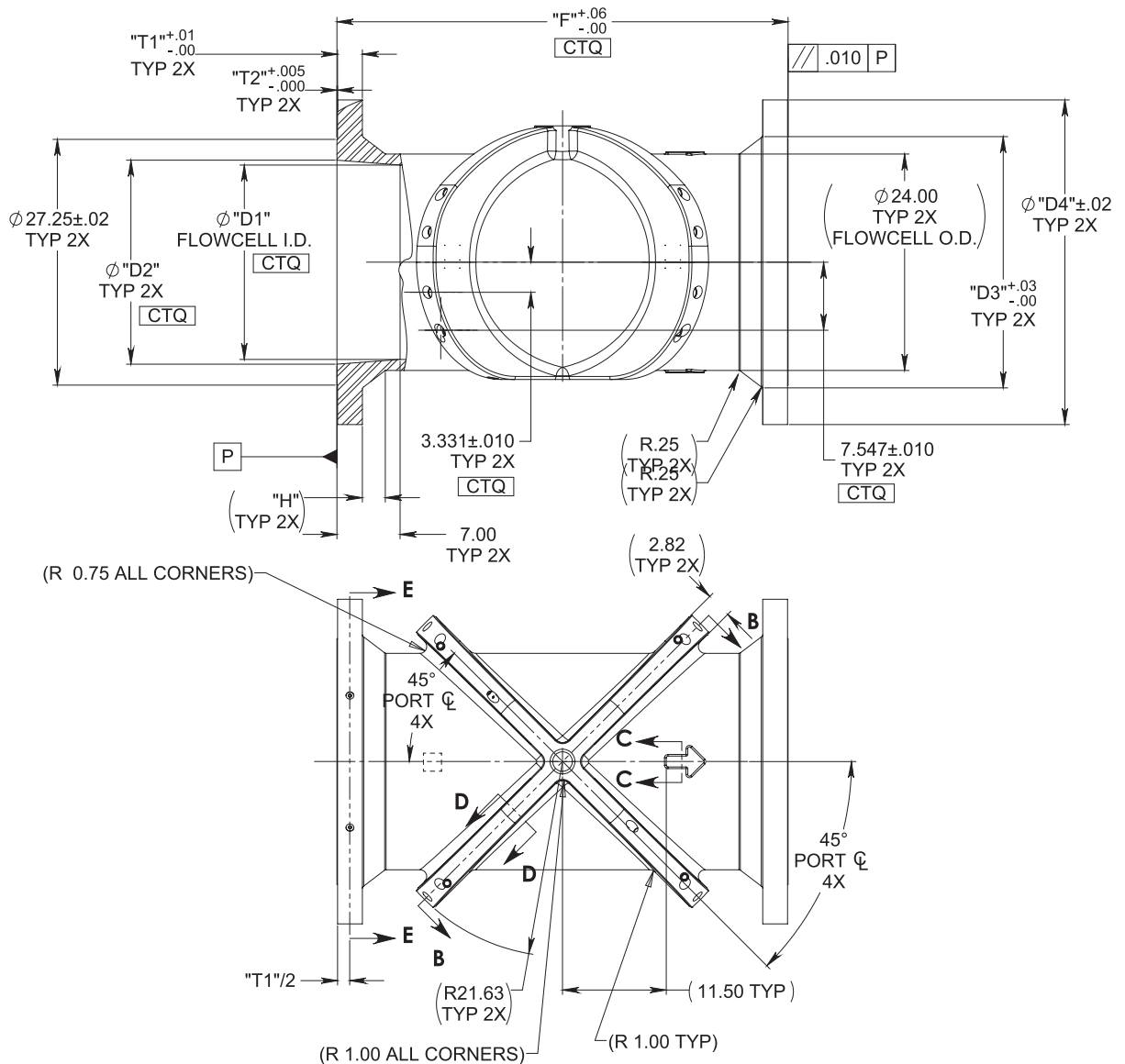

Specifications

Diameter (inches)	Flowcell Dimensions						
	Dimensions in English Units (Rounded)				Dimensions in Metric Units (Rounded)		
	Flange Class	L (in)	H2 (in)	A (in)	L (mm)	H2 (mm)	A (mm)
6	150#	22	23	15.97	559	563	406
	300#	24	23	15.97	610	582	406
	600#	26	24	15.97	660	601	406
8	150#	26	25	16.86	660	621	428
	300#	28	26	16.86	711	640	428
	600#	30	26	16.86	762	659	436
10	150#	28	27	19.14	711	675	486
	300#	30	28	19.14	762	694	486
	600#	32	29	20.00	813	726	508
12	150#	30	29	20.97	762	732	533
	300#	32	30	20.97	813	751	533
	600#	36	31	22.00	914	770	559
14	150#	36	32	22.39	914	792	567
	300#	38	33	23.00	965	818	584
	600#	40	33	23.75	1016	828	603
16	150#	38	35	23.88	965	882	605
	300#	40	36	25.50	1016	908	648
	600#	42	37	27.00	1067	927	686
18	150#	38	38	26.56	965	945	675
	300#	40	39	28.00	1016	983	711
	600#	44	41	29.25	1118	1037	743
20	150#	46	39	28.88	1168	983	734
	300#	48	41	30.50	1219	1021	775
	600#	50	43	32.00	1270	1078	813
24	150#	48	43	32.38	1219	1088	822
	300#	50	45	36.00	1270	1138	914
	600#	52	46	37.00	1321	1151	940

Operation and Performance

Fluid Types

Liquid hydrocarbons, crude and refined products, other liquids

Linearity

± 0.12% of measured volume for flow rates between 1 and 33 ft/s (0.3 and 10 m/s)

Repeatability

0.02%

Uncertainty

± 0.027% according to API MPMS 5.8

Viscosity Range

0 to 660 cSt

Reynolds Range

> Re 10,000, consult GE for lower Reynolds numbers

Process Temperature

Standard; -40 to +140°C (-40 to +248°F)

Ambient Temperature

-40 to +60°C (-40 to 140°F)

Storage Temperature

-40 to +85°C (-40 to +176°F)

Meter Body

Meter Body Materials

- Carbon steel SA216 Gr. WCB (Carbon Steel)
- Low temperature carbon steel SA352 Gr. LCB (Low Temp Carbon Steel)
- Stainless steel SA351 Gr. CF8 (304SS)
- Stainless steel SA351 Gr CF8M (316SS)
- Other materials available upon request

Pipe Sizes

6 in. to 24 in.

Flange Ratings

- 150 #
- 300 #
- 600 #

Pipe Schedules

Standard: 40/40S, 80/80S and OS

Optional: STD, XS and others available upon request

Recommended Installation Requirement

Minimum 5 pipe diameters upstream and 3 pipe diameters downstream

Electronics

Electronics Enclosure Material

Standard: Epoxy coated aluminium

Optional: Stainless steel A351, Gr 316/316L

Environmental Protection

IP66

Power Supply

- 100 to 240 VAC
- 12 to 32 VDC

Power Consumption

7 W

Display

High-contrast 128 x 64 pixel LED graphical display

Outputs

- Two isolated frequency/pulse outputs
- Two alarm relays
- One 4/20 mA output

Inputs

- Two 4/20 mA inputs and one 100 ohm RTD input for temperature, pressure and density input (optional)
- Three 4/20 mA inputs for temperature, pressure and density input (optional)

Digital Interfaces

- PanaLink over RS232/485/USB
- Modbus RTU over RS232/485

Flow Computer Functionality

Integrated flow computer with full P and T volume corrections according to API 11.1

Hazardous Area Certifications

- USA/Canada: Class 1, Div 1, Groups B, C, & D
- Europe: ATEX II 2 G Ex d IIB+H2 (Ex de as option)
- IEC Ex: Ex d IIB+H2 (Ex de as option)

CE Compliance

2004/108/EC EMC Directive

2006/95/EC LVD Directive

Custody Transfer Performance Approvals

Multiple country-specific approvals available upon request.



www.gemeasurement.com

920-673A