

# Series T

## General Eastern Differential Pressure Transmitters



The Series T family of differential pressure transmitters measure low pressures and feature low power consumption and a variety of analog signal outputs. A wide selection of standard pressure ranges and electrical ratings is available.

These transmitters feature: no moving parts to wear out, reliable long term stability, and are virtually position insensitive.

The Series T transmitters are an excellent choice for many HVAC, process and automation monitoring requirements. These transmitters monitor: filter differential pressures, fan static pressures, clean room pressures, variable air volume systems and velocity pressures. They have been used for bubbler level systems, leak detection and in medical and analytical instruments.

The transmitters are housed in a flame retardant, glass-reinforced polyphenylene oxide (NORYL™) case. Electrical connections are made by means of a 3/8 in terminal strip with #6 screws.

The Series T includes four models: Model T10, Model T20, Model T30 and Model T40. These four models incorporate a variety of power and signal options.

The span or zero adjustment is performed with a 20-turn potentiometer for fine resolution.



T10	Three-wire
	DC Voltage In
	DC Voltage Out
T20	Four-wire
	24, 120, or 240 VAC In
	DC Voltage Out
T30	Two-wire
	DC Voltage In
	4 to 20 mA Out
T40	Four-wire
	24, 120, 240 VAC In
	4 to 20 mA Out

The piezoresistive sensor is a solid state device designed in a Wheatstone bridge configuration. When pressure is applied to the device, the resistance of the bridge changes by a small amount. This resistance change is converted to a voltage and amplified.

# Series T Specifications

## General

- Measures differential, gage pressure, or vacuum
- Suitable for air or inert gases
- Maximum safe momentary overpressure: see reference table A

## Performance

### Accuracy

± 1% of span (including non-linearity and hysteresis)

### Calibration

(Traceable to NIST)

## Environmental

### Operating Temperature Range

32°F to 115°F (0°C to 45°C)

### Storage Temperature

-20°F to 160°F (-30°C to 70°C)

### Effect of Temperature

- on zero: ±0.05%/°C
- on span: ±0.02%/°C

### Operating Humidity Range

10% to 90% RH  
non-condensing

### Shock Resistance

10 G (11 ms)

### Vibration Resistance

5 G to 50 Hz

## Electrical Connections

### Connections

External 3/8 in terminal strip with #6 screws

## Physical

### Pressure Port Connections

3/16 in diameter suitable for:

- 1/8 in ID Tygon™ or polyurethane tubing  
0.11 in to 0.15 in (3 mm to 4 mm)
  - 1/4 in OD polyethylene tubing (6 mm)
- Integral filters at both ports

### Dimensions (W x L x H)

3.00 in x 5.15 in x 1.40 in  
(76 mm x 131 mm x 36 mm)

### Material

Flame retardant, glass-reinforced polyphenylene oxide (NORYL) case

### Weight

0.42 lbs (190 g) maximum



# Model T20 Specifications

## AC Power Input/Voltage Output

## Electrical

Transformer isolation between power supply and output is 2500 Vrms

### Output Voltage

- 0 to 5 Volts
- 0 to 10 Volts
- Sink or source 3.5 mA
- Protected against short circuit

## Ordering Information

Order Number (See Table below and Reference Table A on page 8)

T20 - PPP - S - V - O

Example: T20 - 07P - C - X - B

PPP = Pressure Range S = Supply Voltage V = Voltage Output O = Offset  
(See Note)

See Table Reference A C = 24 VAC 5 = 0 to 5 Volts 0 = No offset  
D = 120 VAC X = 0 to 10 Volts A = 1/4 offset  
E = 240 VAC B = 1/2 offset

If the measured differential pressure is expected to go from positive to negative, a transmitter with offset (elevated zero) should be ordered.

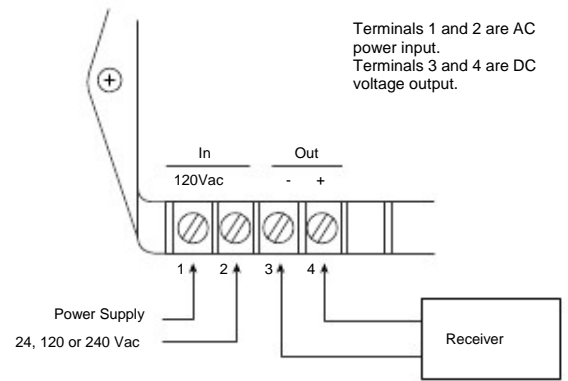

Three options are available:

“0” No offset. At zero differential pressure the output signal is:

0 V (0 to 5 V range)

0 V (0 to 10 V range)

Pressure excursion: 0% to 100% of Range, see Table A

“A” 1/4 span offset. At zero differential pressure the output signal is:

1.25 V (0 to 5 V range)

2.5 V (0 to 10 V range)

Pressure excursion: -33% to 100% of Range, see Table A

“B” 1/2 span offset. At zero differential pressure the output signal is:

2.5 V (0 to 5 V range)

5 V (0 to 10 V range)

Pressure excursion: -100% to 100% of Range see Table A

To order: determine the positive pressure range; from Table A find the corresponding pressure code, then add the required offset (none, A, or B).

For example, T30 05E A is a transmitter with a maximum range of 1 in (25.40 mm) of H<sub>2</sub>O at 20 mA and a minimum range of -0.33 in of H<sub>2</sub>O at 4 mA.

# Model T30 Specifications

Two Wire / 4 to 20 mA Output

## Electrical

- Supply Voltage: 11 to 32 VDC  
(See diagram right for maximum loop resistance)
- Protected against reversal of polarity
- Output limited to approx. 3.85 mA at low end of span and approx. 25 mA at upper end of span

## Ordering Information

Order Number (See Table below and Reference Table A on page 8)

T30 - PPP - O

Example: T30 - 06E - B

PPP = Pressure Range @ = Offset  
(See Note)  
See Reference Table A 0 = No offset  
A = 1/4 offset  
B = 1/2 offset

If the measured differential pressure is expected to go from positive to negative, a transmitter with offset (elevated zero) should be ordered.

Three options are available:

“0” No offset. At zero differential pressure the output signal is:  
4 mA (4 to 20 mA range)  
Pressure excursion: 0% to 100% of Range, see Table A

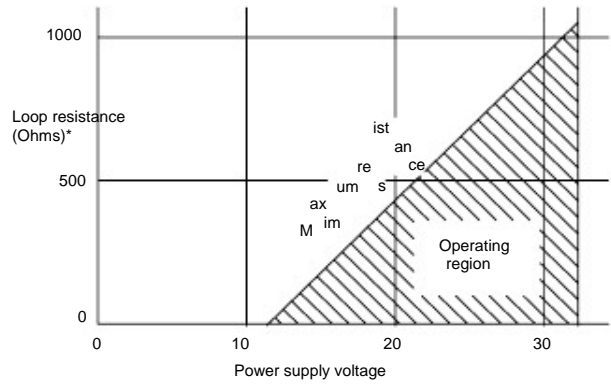

\* Loop resistance = Wire res. + Receiver res.

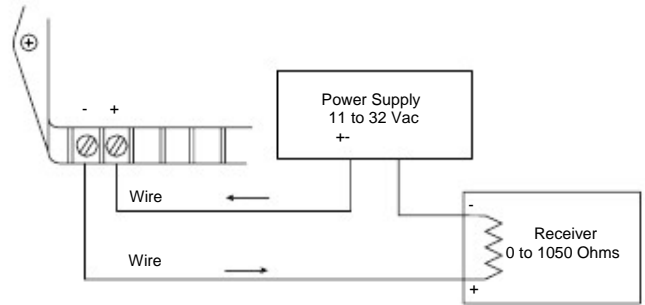

- “A” 1/4 span offset. At zero differential pressure the output signal is:  
8 mA (4 to 20 mA range)  
Pressure excursion: -33% to 100% of Range, see Table A
- “B” 1/2 span offset. At zero differential pressure the output signal is:  
12 mA (4 to 20 mA range)  
Pressure excursion: -100% to 100% of Range see Table A

To order: determine the positive pressure range; from Table A find the corresponding pressure code, then add the required offset (none, A, or B).

For example, T30 05E A is a transmitter with a maximum range of 1 in (25.40 mm) of H<sub>2</sub>O at 20 mA and a minimum range of -0.33 in of H<sub>2</sub>O at 4 mA.

# Model T40 Specifications

AC Power Input / 4 to 20 mA Output

## Electrical

Nominal Input Voltage Voltage Range	Power Consumption	Operating
24 VAC, 50/60Hz	1.5 W	20 to 30 VAC
120 VAC, 50/60Hz	1.5 W	100 to 140 VAC
240 VAC, 50/60Hz	1.5 W	200 to 260 VAC

- Transformer isolation between power supply and output is 2500 Vrms
- Receiver resistance can be from 0 to 600 W
- Output limited to approx. 27 mA at the upper end of span

## Ordering Information

Order Number (See Table below and Reference Table A on page 8)

T40 - PPP - S - O

Example: T40 - 03M - E - B

PPP = Pressure Range S = Supply Voltage O = Offset  
(See Note)

See Reference Table A C = 24 VAC0 = No offset

D = 120 VACA = 1/4 offset

E = 240 VACB = 1/2 offset

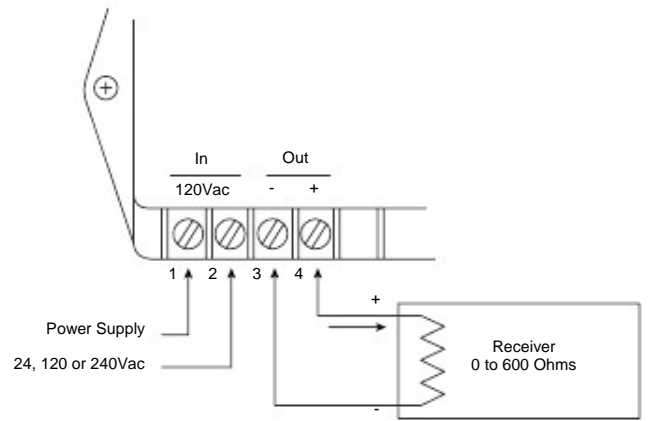

If the measured differential pressure is expected to go from positive to negative, a transmitter with offset (elevated zero) should be ordered.

Three options are available:

"0" No offset. At zero differential pressure the output signal is:

4 mA (4 to 20 mA range)

Pressure excursion: 0% to 100% of Range, see Table A

"A" 1/4 span offset. At zero differential pressure the output signal is:

8 mA (4 to 20 mA range)

Pressure excursion: -33% to 100% of Range, see Table A

"B" 1/2 span offset. At zero differential pressure the output signal is:

12 mA (4 to 20 mA range)

Pressure excursion: -100% to 100% of Range see Table A

To order: determine the positive pressure range; from Table A find the corresponding pressure code, then add the required offset (none, A, or B).

For example, T30 05E A is a transmitter with a maximum range of 1 in (25.40 mm) of H<sub>2</sub>O at 20 mA and a minimum range of -0.33 in of H<sub>2</sub>O at 4 mA.

# Table A - Standard Pressure Ranges

English			Metric Units					
Pressure Code	Pressure Range	Maximum Safe Momentary Overpressure	Pressure Code	Pressure Range	Maximum Safe Momentary Overpressure	Pressure Code	Pressure Range	Maximum Safe Momentary Overpressure
Code	English	Overpressure	Code	Pascals	Overpressure	Code	Pascals	Overpressure
03E	0 to 0.300 in H <sub>2</sub> O		03P	0 to 75.0 Pa		03M	0 to 7.50 mm H <sub>2</sub> O	
04E	0 to 0.500 in H <sub>2</sub> O		04P	0 to 100.0 Pa		04M	0 to 10.00 mm H <sub>2</sub> O	
05E	0 to 1.00 in H <sub>2</sub> O		05P	0 to 250 Pa		05M	0 to 25.0 mm H <sub>2</sub> O	
06E	0 to 2.00 in H <sub>2</sub> O	20 in H <sub>2</sub> O	06P	0 to 500 Pa	5 kPa	06M	0 to 50.0 mm H <sub>2</sub> O	500 mm
07E	0 to 3.00 in H <sub>2</sub> O		07P	0 to 750 Pa		07M	0 to 75.0 mm H <sub>2</sub> O	
08E	0 to 5.00 in H <sub>2</sub> O		08P	0 to 1.00 kPa		08M	0 to 100 mm H <sub>2</sub> O	
09E	0 to 10.0 in H <sub>2</sub> O	5 psid	09P	0 to 2.50 kPa	35 kPa	09M	0 to 250 mm H <sub>2</sub> O	3.5 m



[www.ge-mcs.com](http://www.ge-mcs.com)

920-362D