

The Modus W Series pressure transmitters are designed to measure low differential pressures of liquids or gases. A wide selection of standard pressure ranges and electrical ratings is available.

These transmitters feature no moving parts to wear out, a proven long term stability of piezoresistive devices, only 316 stainless steel in contact with the fluid, and an all-welded construction.

Modus W Series transmitters are an excellent choice for many HVAC, process and automation monitoring requirements. Typical applications include measurement of differential pressure across flow elements, heat exchangers, pumps and filters, liquid level monitoring and other demanding differential pressure measurement and control applications.

The transmitters are housed in a compact, heavy duty, gasketed, cast aluminum enclosure designed to IP 65 of IEC 529 standards and Type 4. The die cast aluminum enclosure incorporates a recessed neoprene gasket to prevent the ingress of moisture or dust. Wall mounting holes are enclosed in the cast aluminum box and concealed by the cover. The wall mounting holes and the cover attaching screws are outside the gasketed area. Access to the electrical terminals are made through knockouts on the front of the box. A choice of two knockouts and three hole sizes are available to accommodate usage of 0.5 in (12.7 mm) conduit or metric sizes PG11 and PG13.

Pluggable terminal block connectors are provided with wire protection and captive terminal screws.

The Modus W Series includes one model: Model W30.

# Modus W Series

## General Eastern Liquid Differential Pressure Transmitters

Modus W Series is a General Eastern product. General Eastern has joined other GE high-technology sensing businesses under a new name—GE Industrial, Sensing.



# GE Sensing

This model is available with the following power and signal configuration

## *Model W30*

- Two-wire
- DC Voltage In
- 4 to 20 mA out

The span or zero adjustment is performed with a 20-turn potentiometer for fine resolution. A 50% adjustment in output is possible.

The Series W transmitters comply with the European requirements of Council Directive 89/336/EEC.

---

## Operation

The pressure transmitter consists of two high accuracy piezoresistive sensors with stainless steel isolation diaphragms. Both sensors measure static pressure, and the difference between these two measurements is computed electronically. The use of high accuracy and stable sensors makes this measurement possible. Since each sensor measures the full static pressure, there is no possibility of over-pressurizing the transmitter if one sensor is disconnected from the line. No complex and/or expensive balancing valves are needed.

---

# W Series Specifications

## Performance

### Accuracy

±1/2% of differential pressure range (includes non-linearity and hysteresis) or ±1% for 6 psid (50 kPa) range

### Effect of Static Pressure on Differential Pressure Measurement

Less than ±0.25% for static pressure change from 0 to 100% or ±0.5% for 6 psid (50 kPa) range

### Calibration

Traceable to National Institute of Standards and Technology (NIST)

## Environmental

Process wetted surfaces are 316 stainless steel.

### Operating Temperature Range

32°F to 122°F (0°C to 50°C)

### Storage Temperature

-20°F to 160°F (-30°C to 70°C)

### Effect of Temperature

- On zero: ±0.05%/°C or ±0.1%/°C for 6 psid (50 kPa) range
- On span: ±0.03%/°C or ±0.06%/°C for 6 psid (50 kPa) range

### Operating Humidity Range

10% to 90% RH, non-condensing

### Shock Resistance

10 G (11 ms)

### Vibration Resistance

5 G 3 to 50 Hz

## Electrical Connectors

Polarized Euro plug/connectors.

### Connections

Pluggable terminal block for wire 14 to 26 AWG. Mating connector is supplied

Connection to enclosure ground is provided.

### Connector rating

10 Amps/300 V

### Material

Glass-filled polyester

## Physical

### Dimensions

3.56 in x 4.54 in x 2.18 in (90 mm x 115 mm x 55 mm)

### Enclosure material

Aluminum Alloy #A380

### Cover screws

M4 stainless steel non-magnetic

### Finish

Black epoxy paint

### Knockout

- Choice of 2 holes
- Hole sizes are offered in a choice of 1/2 in (12.7 mm) conduit or metric sizes of PG11 or PG13.
- Cable glands not included.

### Pressure port connections

1/8-28 female NPT

### Weight

1.2 lb (540 g)

# W30 Series Specifications

## Electrical

### Supply Voltage

11 to 32 VDC (See diagram for maximum loop resistance)

### Output

Two-wire/4 to 20 mA output

Protected against reversal of polarity. Output limited to approximately 3.85 mA at low end of span and approximately 25 mA at upper end of span.

## Standard Pressure Ranges for Modus W Series

### US Units

Pressure Code	Differential Pressure Range, psid	Operating Static Pressure, psi
31E	0 to 6 psi	-
32E	0 to 10 psi	0 to 100 psi
33E	0 to 15 psi	-
34E	0 to 30 psi	-
35E	0 to 60 psi	-
36E	0 to 100 psi	0 to 300 psi
37E	0 to 150 psi	-
38E	0 to 200 psi	-

### Metric Units, Millimeters of Water

Pressure Code	Differential Pressure Range, k mm H <sub>2</sub> O	Operating Static Pressure, k mm H <sub>2</sub> O
31M	0 to 5.0 k mm H <sub>2</sub> O	-
32M	0 to 7.5 k mm H <sub>2</sub> O	0 to 70 k mm H <sub>2</sub> O
33M	0 to 10 k mm H <sub>2</sub> O	-
34M	0 to 20 k mm H <sub>2</sub> O	-
35M	0 to 50 k mm H <sub>2</sub> O	-
36M	0 to 75 k mm H <sub>2</sub> O	0 to 200 k mm H <sub>2</sub> O
37M	0 to 100 k mm H <sub>2</sub> O	-
38M	0 to 150 k mm H <sub>2</sub> O	-



©2006 GE. All rights reserved.  
920-301A

All specifications are subject to change for product improvement without notice. GE® is a registered trademark of General Electric Co. Other company or product names mentioned in this document may be trademarks or registered trademarks of their respective companies, which are not affiliated with GE.

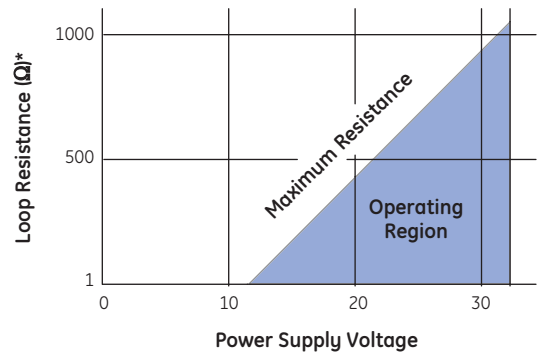

\*Loop resistance = wire resistance + receiver resistance

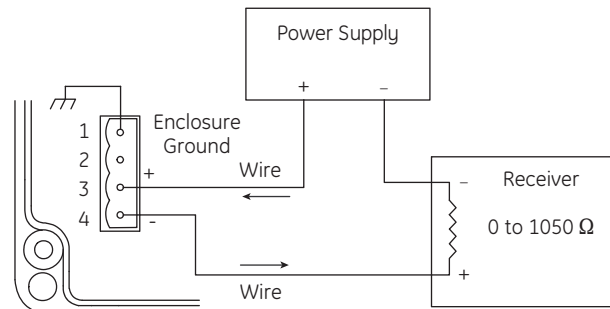

Modus W30 Series schematic diagram

### Metric Units Pascal

Pressure Code	Differential pressure Range, kPa	Operating Static Pressure, kPa
31P	0 to 50 Pa	-
32P	0 to 75 Pa	0 to 700 kPa*
33P	0 to 100 Pa	-
34P	0 to 200 Pa	-
35P	0 to 500 Pa	-
36P	0 to 750 Pa	0 to 2000 kPa
37P	0 to 1000 Pa	-
38P	0 to 1500 Pa	-

## Ordering Information

Record selected option in blank indicated at bottom of form.

W30

↓	Code	Pressure Range (PPP)
↓	X	See Standard Pressure Ranges Tables
↓	Code	Knockout Quantity (KQ)
↓	2	Two holes
↓	Code	Knockout Size (KS)
↓	R	1/2 in (12.7 mm) conduit
↓	S	PG 11

W30 - - - - Typical model number.